

The 8085 Microprocessor

1. Draw the pin configuration and functional pin diagram of μP 8085.

Ans. The pin configuration and functional pin diagram of μP 8085 are shown below:

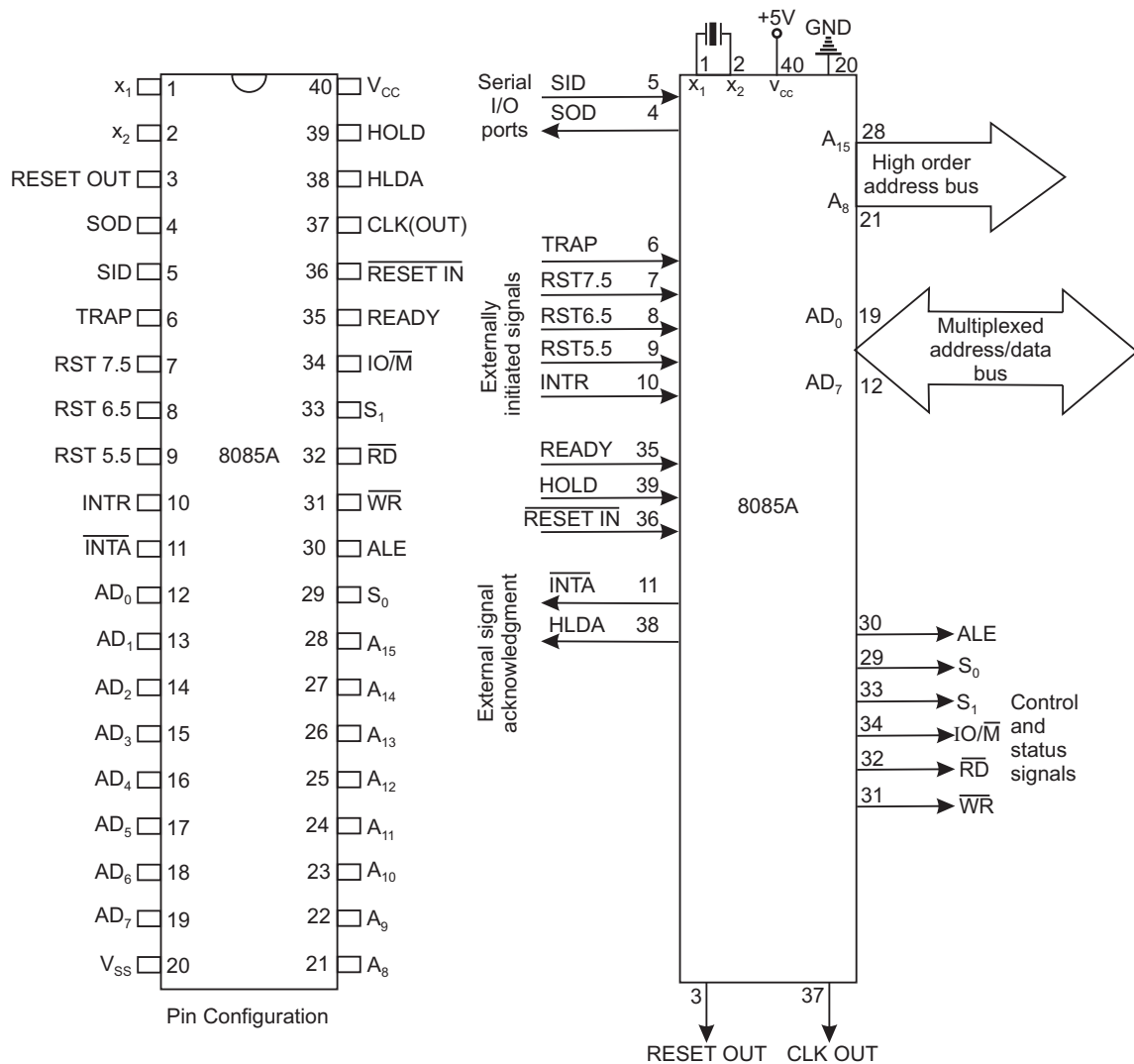

Fig. 2.1: Functional pin diagram

2. In how many groups can the signals of 8085 be classified?

Ans. The signals of 8085 can be classified into seven groups according to their functions. These are:

- (1) Power supply and frequency signals
- (2) Data and Address buses
- (3) Control bus
- (4) Interrupt signals
- (5) Serial I/O signals
- (6) DMA signals
- (7) Reset signals.

3. Draw the architecture of 8085 and mention its various functional blocks.

Ans. The architecture of 8085 is shown below:

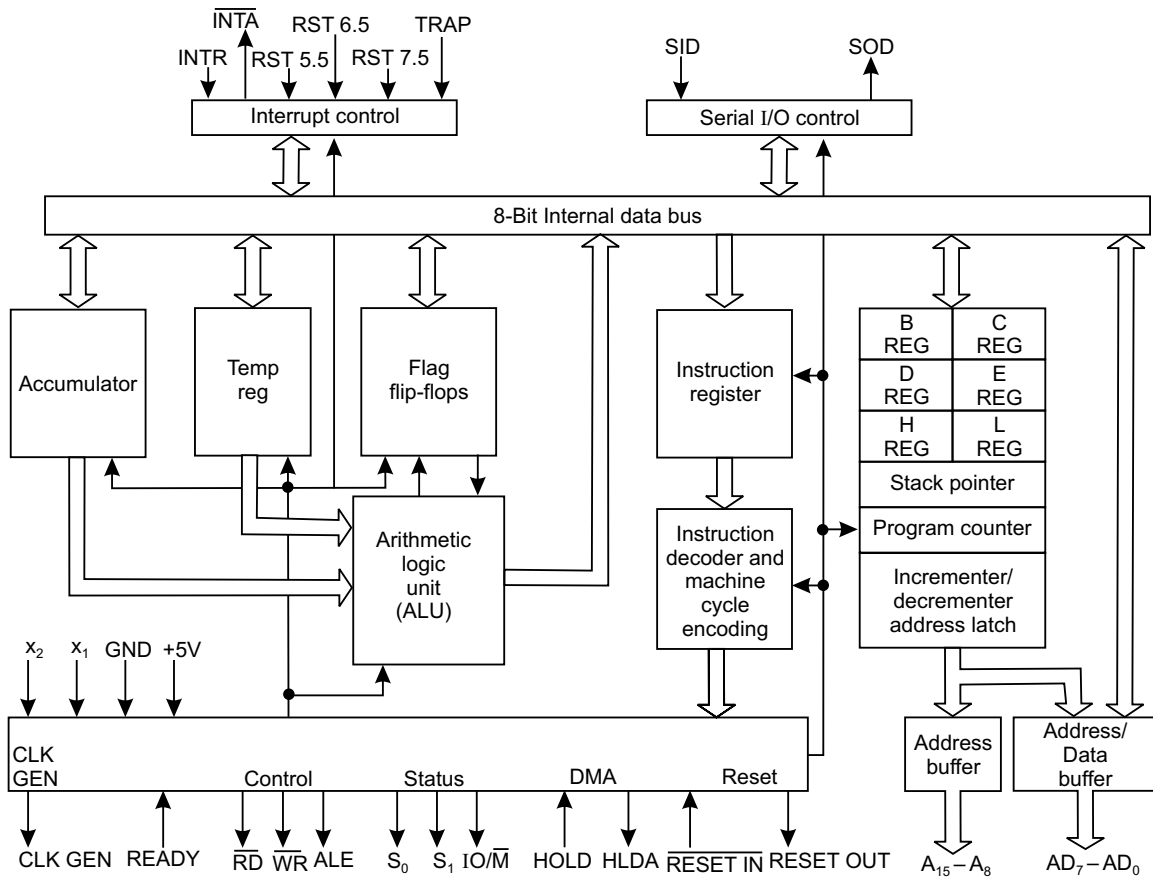

Fig. 2.2: Architecture of 8085

The various functional blocks of 8085 are as follows:

- Registers
- Arithmetic logic unit
- Address buffer
- Incrementer/decrementer address latch
- Interrupt control
- Serial I/O control
- Timing and control circuitry
- Instructions decoder and machine cycle encoder.

4. What is the technology used in the manufacture of 8085?

Ans. It is an NMOS device having around 6200 transistors contained in a 40 pin DIP package.

5. What is meant by the statement that 8085 is a 8-bit microprocessor?

Ans. A microprocessor which has n data lines is called an n-bit microprocessor i.e., the width of the data bus determines the size of the microprocessor. Hence, an 8-bit microprocessor like 8085 can handle 8-bits of data at a time.

6. What is the operating frequency of 8085?

Ans. 8085 operates at a frequency of 3 MHz, and the minimum frequency of operation is 500 kHz.

The version 8085 A-2 operates at a maximum frequency of 5 MHz.

7. Draw the block diagram of the built-in clock generator of 8085.

Ans. The built-in clock generator of 8085, in block schematic, is shown below:

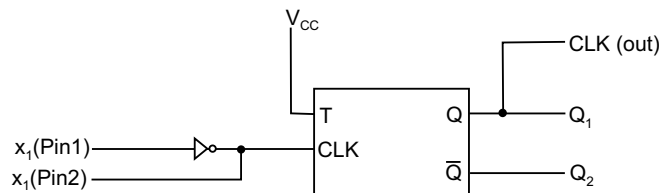

Fig. 2.3: Block diagram of built-in clock generator

The internal built-in clock generator, LC or RC tuned circuits, piezo-electric crystal or external clock source acts as an input to generate the clock. The T F/F, shown in Fig. 2.3 divides the input frequency by 2. Thus the output frequency of 8085 (obtained from pin 37) is half the input frequency.

8. What is the purpose of CLK signal of 8085?

Ans. The CLK (out) signal obtained from pin 37 of 8085 is used for synchronizing external devices.

9. Draw the different clock circuits which can be connected to pins 1 and 2 of 8085.

Ans. The different external clock circuits which can be connected to pins 1 and 2 of 8085 are shown below in Fig. 2.4:

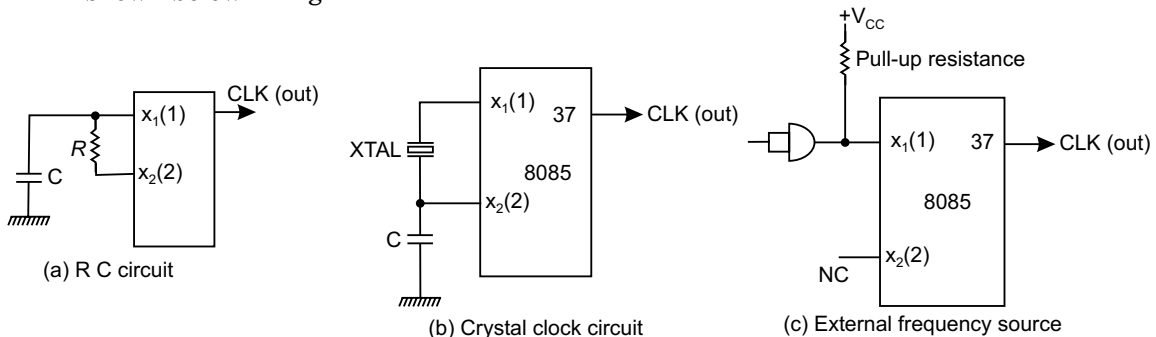

Fig. 2.4: The different external clock circuits

The output frequency obtained from pin 37 of Fig. 2.4(b) is more stable than the RC circuit of Fig. 2.4(a).

10. What are the widths of data bus (DB) and address bus (AB) of 8085?

Ans. The width of DB and AB of 8085 are 8-bits (1 byte) and 16-bits (2 bytes) respectively.

11. What is the distinguishing feature of DB and AB?

Ans. While the data bus is bidirectional in nature, the address bus is unidirectional.

Since the μP can input or output data from within it, hence DB is bidirectional. Again the microprocessor addresses/communicates with peripheral ICs through the address bus, hence it is unidirectional, the address comes out via the AB of μP .

12. The address capability of 8085 is 64 KB. Explain.

Ans. Microprocessor 8085 communicates via its address bus of 2-bytes width – the lower byte $\text{AD}_0 - \text{AD}_7$ (pins 12-19) and upper byte $\text{D}_8 - \text{D}_{15}$ (pins 21-28). Thus it can address a maximum of 2^{16} different address locations. Again each address (memory location) can hold 1 byte of data/instruction. Hence the maximum address capability of 8085 is

$$\begin{aligned} &= 2^{16} \times 1 \text{ Byte} \\ &= 65,536 \times 1 \text{ Byte} \\ &= 64 \text{ KB} \quad (\text{where } 1 \text{ K} = 1024 \text{ bytes}) \end{aligned}$$

13. Does 8085 have serial I/O control?

Ans. 8085 has serial I/O control via its SOD and SID pins (pins 4 and 5) which allows it to communicate serially with external devices.

14. How many instructions 8085 can support?

Ans. 8085 supports 74 different instructions.

15. Mention the addressing modes of 8085.

Ans. 8085 has the following addressing modes: Immediate, Register, Direct, Indirect and Implied.

16. What jobs ALU of 8085 can perform?

Ans. The Arithmetic Logic Unit (ALU) of 8085 can perform the following jobs:

- 8-bit binary addition with or without carry.
- 16-bit binary addition.
- 2-digit BCD addition.
- 8-bit binary subtraction with or without borrow.
- 8-bit logical OR, AND, EXOR, complement (NOT function).
- bit shift operation.

17. How many hardware interrupts 8085 supports?

Ans. It supports five (5) hardware interrupts—TRAP, RST 7.5, RST 6.5, RST 5.5 and INTR.

18. How many I/O ports can 8085 access?

Ans. It provides 8-bit I/O addresses. Thus it can access $2^8 = 256$ I/O ports.

19. Why the lower byte address bus ($A_0 - A_7$) and data bus ($D_0 - D_7$) are multiplexed?

Ans. This is done to reduce the number of pins of 8085, which otherwise would have been a 48 pin chip. But because of multiplexing, external hardware is required to demultiplex the lower byte address cum data bus.

20. List the various registers of 8085.

Ans. The various registers of 8085, their respective quantities and capacities are tabulated below:

Table 2.1: List of Various Registers in 8085

S. No.	Name of the Register	Quantity	Capacity
1.	Accumulator (or) Register A	1	8-bit
2.	Temporary register	1	8-bit
3.	General purpose registers (B, C, D, E, H and L)	6	8-bit each
4.	Stack pointer (SP)	1	16-bit
5.	Program counter (PC)	1	16-bit
6.	Instruction register	1	8-bit
7.	Incrementer/Decrementer address latch	1	16-bit
8.	Status flags register	1	8-bit

21. Describe the accumulator register of 8085.

Ans. This 8-bit register is the most important one amongst all the registers of 8085. Any data input/output to/from the microprocessor takes place via the accumulator (register). It is generally used for temporary storage of data and for the placement of final result of arithmetic/logical operations.

Accumulator (ACC or A) register is extensively used for arithmetic, logical, store and rotate operations.

22. What are the temporary registers of 8085?

Ans. The temporary registers of 8085 are temporary data register and W and Z registers. These registers are not available to the programmer, but 8085 uses them internally to hold temporary data during execution of some instructions.

23. Describe W and Z registers of 8085.

Ans. W and Z are two 8-bit temporary registers, used to hold 8-bit data/address during execution of some instructions.

CALL-RET instructions are used in subroutine operations. On getting a CALL in the main program, the current program counter content is pushed into the stack and loads the PC with the first memory location of the subroutine. The address of the first memory location of the subroutine is temporarily stored in W and Z registers.

Again, XCHG instruction exchanges the contents H and L with D and E respectively. W and Z registers are used for temporary storage of such data.

24. Describe the temporary data register of 8085.

Ans. The temporary data register of 8085 is an 8-bit register, which is not available to the programmer, but is used internally for execution of most of the arithmetic and logical operations.

ADD D instruction adds the contents of accumulator with the content of D. The content of D is temporarily brought into the temporary data register. Thus the two inputs to the ALU are—one from the accumulator and the other from the temporary data register. The result is stored in the accumulator.

25. Describe the general purpose registers of 8085?

Ans. The general purpose registers of 8085 are: B, C, D, E, H and L. They are all 8-bit registers but can also be used as 16-bit register pairs—BC, DE and HL. These registers are also known as scratch pad registers.

26. In what other way HL pair can be used?

Ans. HL register pair can be used as a data pointer or memory pointer.

27. Mention the utility of the general purpose registers.

Ans. General purpose registers store temporary data during program execution, which can also be stored in different accessible memory locations. But storing temporary data in memory requires bus access—hence more time is needed to store. Thus it is always advisable to store data in general purpose registers.

The more the number of general purpose registers, the more is flexibility in programming—so a microprocessor having more such registers is always advantageous.

28. Which are the sixteen bit registers of 8085.

Ans. 8085 has three (3) sixteen bit registers—Program Counter (PC), Stack Pointer (SP) and Incrementer/Decrementer address latch register.

29. Discuss the two registers program counter and stack pointer.

Ans. Program counter (PC) is a sixteen bit register which contains the address of the instruction to be executed just next. PC acts as a address pointer (also known as memory pointer) to the next instruction. As the processor executes instructions one after another, the PC is incremented—the number by which the PC increments depends on the nature of the instruction. For example, for a 1-byte instruction, PC is incremented by one, while for a 3-byte instruction, the processor increments PC by three address locations.

Stack pointer (SP) is a sixteen bit register which points to the 'stack'. The stack is an area in the R/W memory where temporary data or return addresses (in cases of subroutine CALL) are stored. Stack is a auto-decrement facility provided in the system. The stack top is initialised by the SP by using the instruction LXI SP, memory address.

In the memory map, the program should be written at one end and stack should be initialised at the other end of the map—this is done to avoid crashing of program. If sufficient

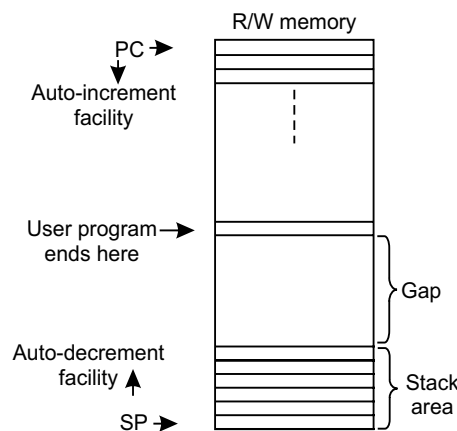

Fig. 2.5: Auto-increment and auto-decrement facility for PC and SP respectively

gap is not maintained between program memory location and stack, then when the stack gets filled up by PUSH or subroutine calls, the stack top may run into the memory area where program has been written. This is shown in Fig. 2.5.

30. Describe the instruction register of 8085.

Ans. Program written by the programmer resides in the R/W memory. When an instruction is being executed by the system, the opcode of the instruction is fetched from the memory and stored in the instruction register. The opcode is loaded into the instruction register during opcode fetch cycle. It is then sent to the instruction decoder.

31. Describe the (status) flag register of 8085.

Ans. It is an 8-bit register in which five bit positions contain the status of five condition flags which are Zero (Z), Sign (S), Carry (CY), Parity (P) and Auxiliary carry (AC). Each of these five flags is a 1 bit F/F. The flag register format is shown in Fig. 2.6:

D7	D6	D5	D4	D3	D2	D1	D0
S	Z	X	AC	X	P	X	CY

Fig. 2.6: The flag register format

- *Sign (S) flag:* – If the MSB of the result of an operation is 1, this flag is set, otherwise it is reset.
- *Zero (Z) flag:*– If the result of an instruction is zero, this flag is set, otherwise reset.
- *Auxiliary Carry (AC) flag:*– If there is a carry out of bit 3 and into bit 4 resulting from the execution of an arithmetic operation, it is set otherwise reset.

This flag is used for BCD operation and is not available to the programmer to change the sequence of an instruction.

- *Carry (CY) flag:*– If an instruction results in a carry (for addition operation) or borrow (for subtraction or comparison) out of bit D₇, then this flag is set, otherwise reset.
- *Parity (P) flag:*– This flag is set when the result of an operation contains an even number of 1’s and is reset otherwise.

32. State the characteristics of the flag register.

Ans. The following are the characteristics of flag register:

- It is an 8-bit register.
- It contains five flags—each of one bit.
- The flag register can’t be written into.

33. What is the purpose of incrementer/decrementer address latch register?

Ans. This 16-bit register increments/decrements the contents of PC or SP when instructions related to them are executed.

34. Mention the blocks on which ALU operates?

Ans. The ALU functions as a part which includes arithmetic logic group of circuits. This includes accumulator, flags F/Fs and temporary register blocks.

35. What is the function of the internal data bus?

Ans. The width of the internal data bus is 8-bit and carries instructions/data between the CPU registers. This is totally separate from the external data bus which is connected to memory chips, I/O, etc.

The internal and external data bus are connected together by a logic called a bidirectional bus (transreceiver).

36. Describe in brief the timing and control circuitry of 8085.

Ans. The T&C section is a part of CPU and generates timing and control signals for execution of instructions. This section includes Clock signals, Control signals, Status signals, DMA signals as also the Reset section. This section controls fetching and decoding operations. It also generates appropriate control signals for instruction execution as also the signals required to interface external devices.

37. Mention the following:

- (a) **Control and Status signals**
- (b) **Interrupt signals**
- (c) **Serial I/O signals**
- (d) **DMA signals**
- (e) **Reset signals.**

Ans. The control and status signals are ALE, \overline{RD} , \overline{WR} , $\overline{IO/\overline{M}}$, S_0 , S_1 and READY.

The interrupt signals are TRAP, RST 7.5, RST 6.5, RST 5.5, INTR. \overline{INTA} is an interrupt acknowledgement signal indicating that the processor has acknowledged an INTR interrupt.

Serial I/O signals are SID and SOD

DMA signals are HOLD and HLDA

Reset signals are $\overline{RESET\ IN}$ and RESET OUT.

38. What is the function of ALE and how does it function?

Ans. Pin 30 of 8085 is the ALE pin which stands for 'Address Latch Enable'. ALE signal is used to demultiplex the lower order address bus ($AD_0 - AD_7$).

Pins 12 to 19 of 8085 are $AD_0 - AD_7$ which is the multiplexed address-data bus. Multiplexing is done to reduce the number of pins of 8085.

Lower byte of address ($A_0 - A_7$) are available from $AD_0 - AD_7$ (pins 12 to 19) during T_1 of machine cycle. But the lower byte of address ($A_0 - A_7$), along with the upper byte $A_8 - A_{15}$ (pins 21 to 28) must be available during T_2 and rest of the machine cycle to access memory location or I/O ports.

Now ALE signal goes high at the beginning of T_1 of each machine cycle and goes low at the end of T_1 and remains low during the rest of the machine cycle. This high to low transition of ALE signal at the end of T_1 is used to latch the lower order address byte ($A_0 - A_7$) by the latch IC 74LS373, so that the lower byte $A_0 - A_7$ is continued to be available till the end of the machine cycle. The situation is explained in the following figure:

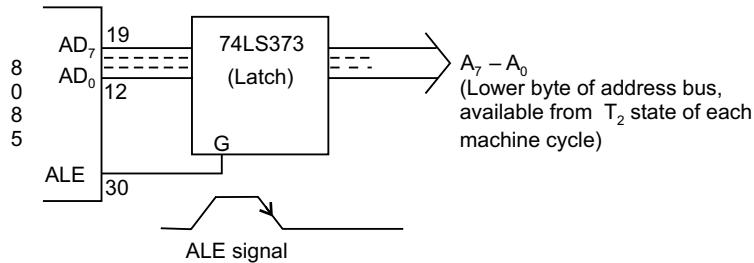

Fig. 2.7: Lower byte of address latching achieved by the H to L transition of ALE signal, which occurs at the end of T_1 of each machine cycle

39. Explain the function of the two DMA signals HOLD and HLDA.

Ans. DMA mode of data transfer is fastest and pins 39 and 38 (HOLD and HLDA) become active only in this mode.

When DMA is required, the DMA controller IC (8257) sends a 1 to pin 39 of 8085. At the end of the current instruction cycle of the microprocessor it issues a 1 to pin 38 of the controller. After this the bus control is totally taken over by the controller.

When 8085 is active and 8257 is idle, then the former is MASTER and the latter is SLAVE, while the roles of 8085 and 8257 are reversed when 8085 is idle and 8257 becomes active.

40. Discuss the three signals $\overline{IO/\overline{M}}$, S_0 and S_1 .

Ans. $\overline{IO/\overline{M}}$ signal indicates whether I/O or memory operation is being carried out. A high on this signal indicates I/O operation while a low indicates memory operation. S_0 and S_1 indicate the type of machine cycle in progress.

41. What happens when $\overline{\text{RESET IN}}$ signal goes low?

Ans. $\overline{\text{RESET IN}}$ is an input signal which is active when its status is low. When this pin is low, the following occurs:

- The program counter is set to zero (0000_H).
- Interrupt enable and HLDA F/Fs are resetted.
- All the buses are tri-stated.
- Internal registers of 8085 are affected in a random manner.

42. Is there any minimum time required for the effective $\overline{\text{RESET IN}}$ signal?

Ans. For proper resetting to take place, the reset signal $\overline{\text{RESET IN}}$ must be held low for at least 3 clock cycles.

43. Indicate the function of RESET OUT signal.

Ans. When this signal is high, the processor is being reset. This signal is synchronised to the processor clock and is used to reset other devices which need resetting.

44. Write the advantages/disadvantages of having more number of general purpose registers in a microprocessor.

Ans. Writing of a program becomes more convenient and flexible by having more number of general purpose registers.

But there are certain disadvantages of having more GPRs. These are as follows:

The more the number of GPRs in a microprocessor, more number of bits would be required to identify individual registers. This would reduce the number of operations that can be provided by the microprocessor.

In programs involving subroutine CALL, if more GPRs are involved, then their status are to be saved in stack and on return from the subroutine, they are to be restored from the stack. This will thus put considerable overhead on the microprocessor.

If more number of GPRs are used in a microprocessor, considerable area of the chip is used up in accommodating the GPRs. Thus there may be some problem in implementing other functions on the chip.

45. Draw the lower and higher order address bus during the machine cycles.

Ans. The lower byte of address ($AD_0 - AD_7$) is available on the multiplexed address/data bus during T_1 state of each machine cycle, except during the bus idle machine cycle, shown in Fig. 2.8.

The higher byte of address ($A_8 - A_{15}$) is available during T_1 to T_3 states of each machine cycle, except during the bus idle machine cycle, shown in Fig. 2.9.

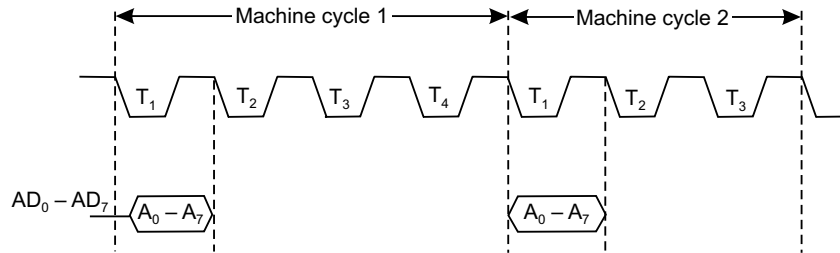

Fig. 2.8: Lower byte address on the multiplexed bus

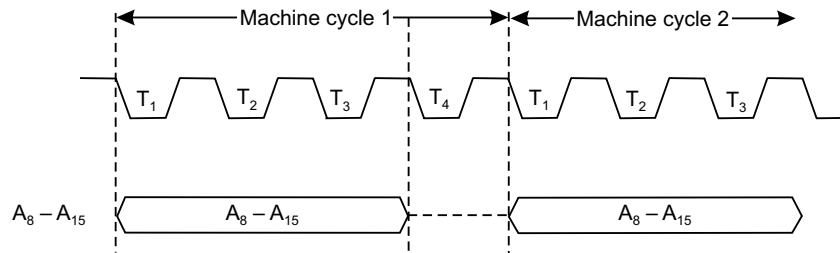

Fig. 2.9: Higher byte address on $A_8 - A_{15}$

46. Draw the appearance of data in the read and write machine cycles.

Ans. Data transfer from memory or I/O device to microprocessor or the reverse takes place during T_2 and T_3 states of the machine cycles.

In the read machine cycle, data appears at the beginning of T_3 state, whereas in the write machine cycle, it appears at the beginning of T_2 , shown in Fig. 2.10.

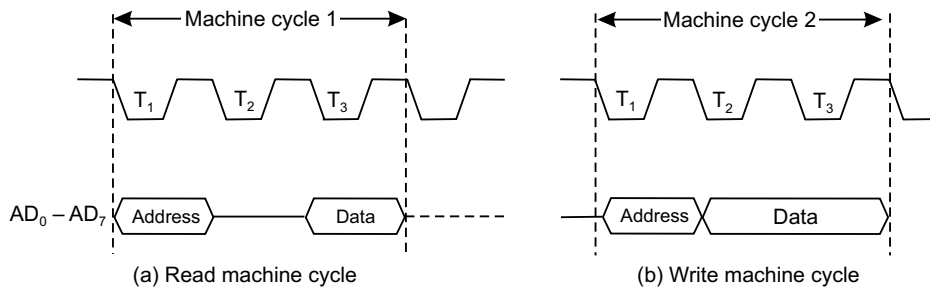

Fig. 2.10: Data bus

47. Draw the status signals during opcode fetch and memory read machine cycles.

Ans. The status signals are $\overline{IO/\overline{M}}$, S_0 and S_1 . Their conditions indicate the type of machine cycle that the system is currently passing through. These three status signals remain active right from the beginning till the end of each machine cycle, shown in Fig. 2.11.

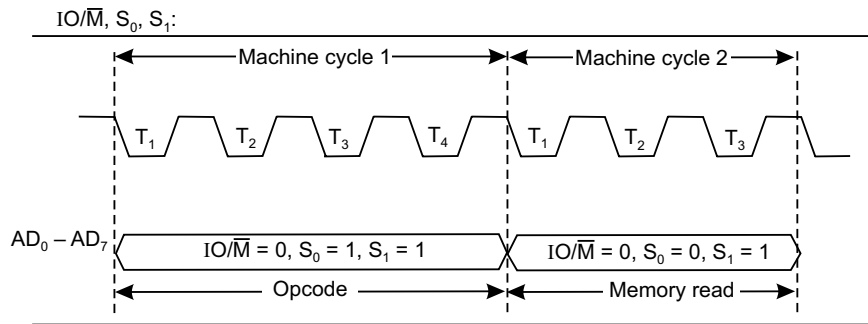

Fig. 2.11: Status signals

48. Show the \overline{RD} and \overline{WR} signals during the Read cycle and Write cycle.

Ans. When \overline{RD} is active, microprocessor reads data from either memory or I/O device while when \overline{WR} is active, it writes data into either memory or I/O device.

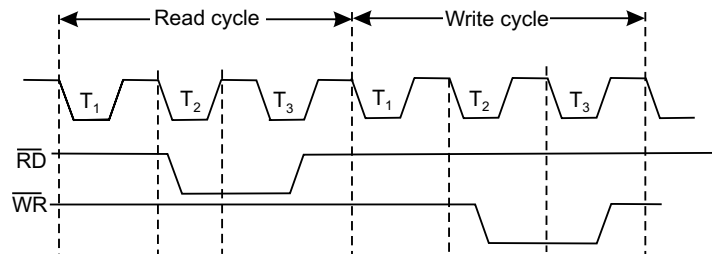

Fig. 2.12: \overline{RD} and \overline{WR} signals

Data transfer (reading/writing) takes place during T_2 and T_3 states of read cycle or write cycle and is shown in Fig. 2.12.

49. Indicate the different machine cycles of 8085.

Ans. 8085 has seven different machine cycles. These are:

- (1) Opcode Fetch (2) Memory Read (3) Memory Write (4) I/O Read (5) I/O Write (6) Interrupt Acknowledge (7) Bus Idle.

50. Draw the Opcode Fetch machine cycle of 8085 and discuss.

Ans. The first machine cycle of every instruction is the Opcode Fetch. This indicates the kind of instruction to be executed by the system. The length of this machine cycle varies between 4T to 6T states—it depends on the type of instruction. In this, the processor places the contents of the PC on the address lines, identifies the nature of machine cycle (by $\overline{IO/\overline{M}}$, S_0 , S_1) and activates the ALE signal. All these occur in T_1 state.

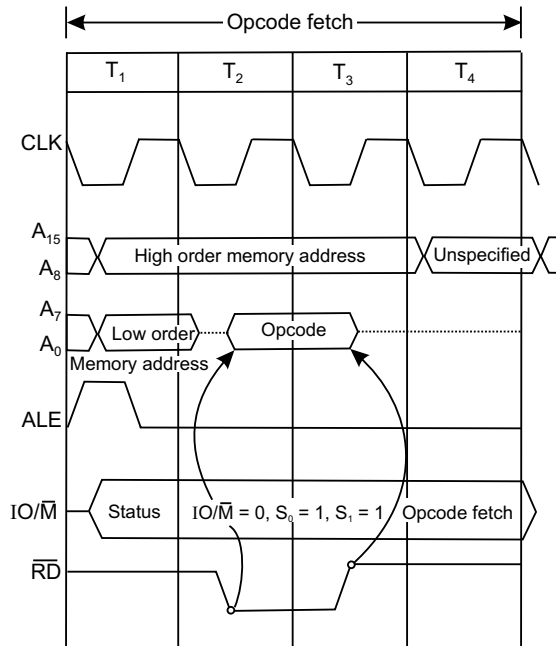

Fig. 2.13: Opcode fetch machine cycle

In T_2 state, \overline{RD} signal is activated so that the identified memory location is read from and places the content on the data bus ($D_0 - D_7$).

In T_3 , data on the data bus is put into the instruction register (IR) and also raises the \overline{RD} signal thereby disabling the memory.

In T_4 , the processor takes the decision, on the basis of decoding the IR, whether to enter into T_5 and T_6 or to enter T_1 of the next machine cycle.

One byte instructions that operate on eight bit data are executed in T_4 . Examples are ADD B, MOV C, B, RRC, DCR C, etc.

51. Briefly describe Memory Read and Write machine cycles and show the waveforms.

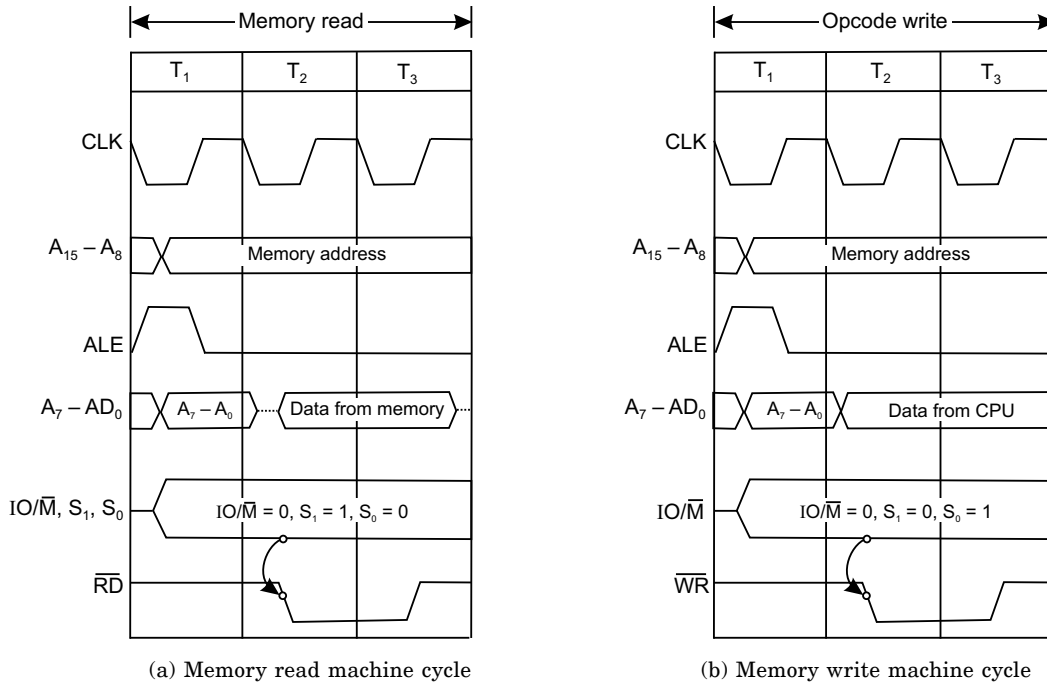

Fig. 2.14: Memory read and write machine cycle

Ans. Both the Memory Read and Memory Write machine cycles are 3T states in length. In Memory Read the contents of R/W memory (including stack also) or ROM are read while in Memory Write, it stores data into data memory (including stack memory).

As is evident from Fig. 2.14 during T₂ and T₃ states data from either memory or CPU are made available in Memory Read or Memory Write machine cycles respectively. The status signal (IO/M, S₀, S₁) states are complementary in nature in Memory Read and Memory Write cycles. Reading or writing operations are performed in T₂.

In T₃ of Memory Read, data from data bus are placed into the specified register (A, B, C, etc.) and raises RD so that memory is disabled while in T₃ of Memory Write WR signal is raised which disables the memory.

52. Draw the I/O Read and I/O Write machine cycles and discuss.

Ans. I/O Read and Write machine cycles are almost similar to Memory Read and Write machine cycles respectively. The difference here is in the IO/M signal status which remains 1 indicating that these machine cycles are related to I/O operations. These machine cycles take 3T states.

In I/O read, data are available in T₂ and T₃ states, while during the same time (T₂ and T₃) data from CPU are made available in I/O write.

The I/O read and write machine cycles are shown in Fig. 2.15.

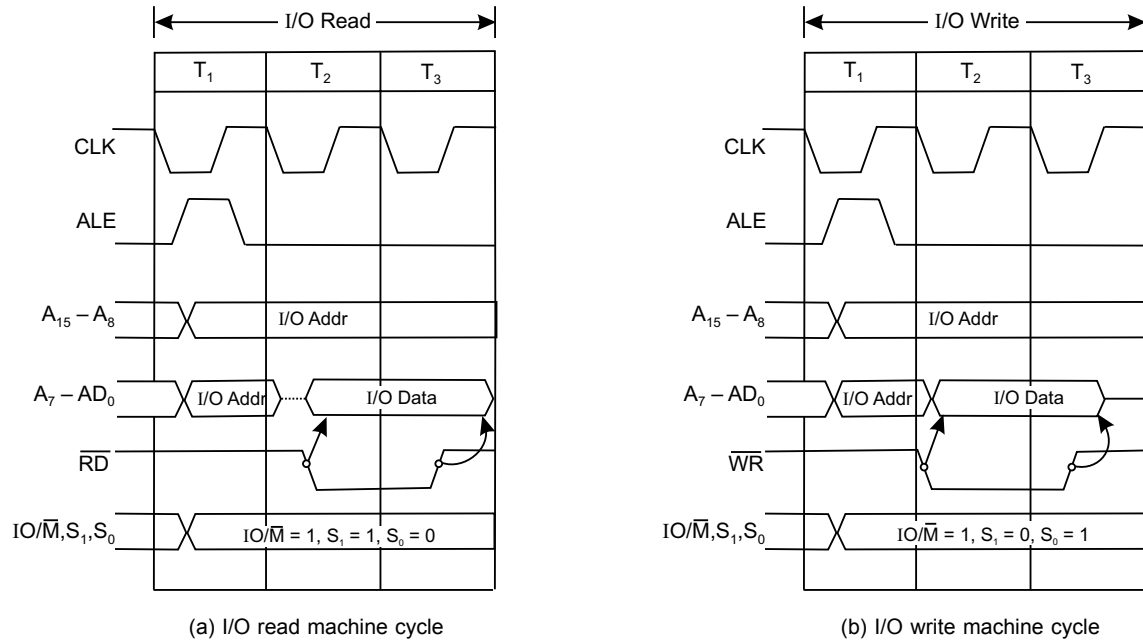

Fig. 2.15: I/O read and write machine cycles

53. Draw the Interrupt Acknowledge cycles for (a) RST instruction (b) CALL instruction.

Ans. The following figure shows the Interrupt Acknowledge cycle for RST instruction.

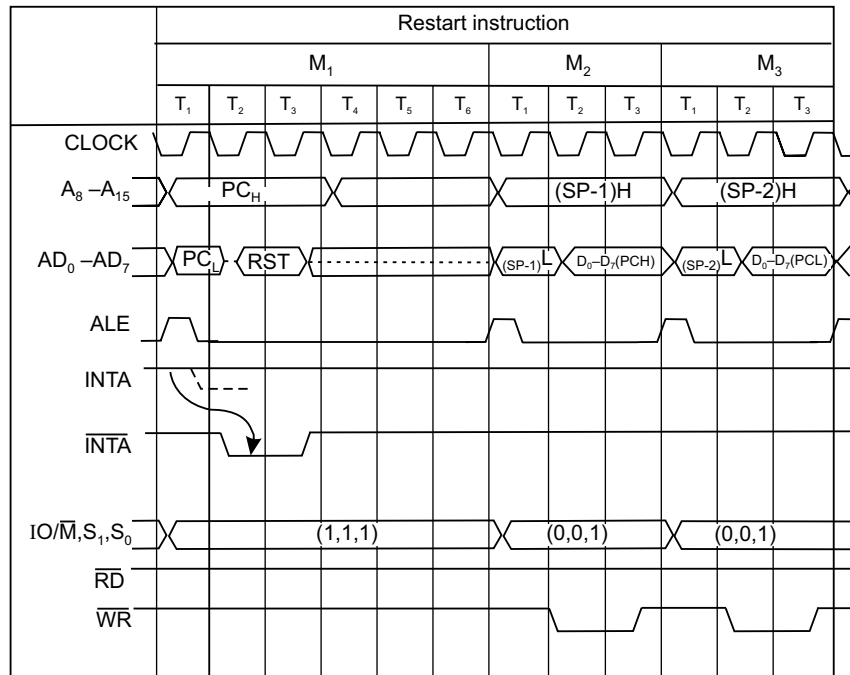

Fig. 2.16: Restart instruction

In M_1 , RST is decoded. This initiates a CALL to the specific vector location. Contents of the PC are stored in stack in machine cycles M_2 and M_3 .

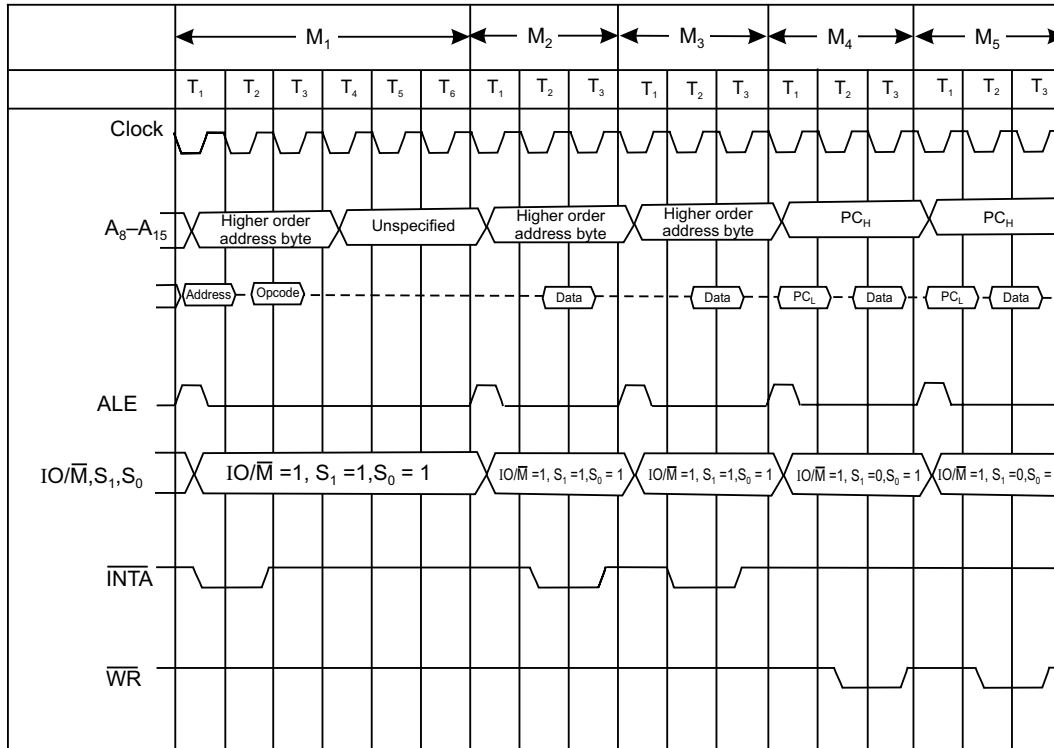

Fig. 2.17: Timing diagram of \overline{INTA} machine cycle and execution of call instruction

The above figure shows an Interrupt Acknowledge cycle for CALL instruction. M_2 and M_3 machine cycles are required to call the 2 bytes of the address following the CALL. Memory write are done in machine cycles M_4 and M_5 in which contents of PC are stored in stack and then a new instruction cycle begins.

54. What is meant by Bus Idle Machine cycle?

Ans. There are a few situations in which machine cycles are neither Read or Written into. These are called Bus Idle Machine cycle.

Such situations arise when the system executes a DAD or during the internal opcode generation for the RST or TRAP interrupts.

The ALE signal changes state during T_1 of each machine cycle, but in Bus Idle Machine cycles, ALE does not change state.

55. Explain the DAD instruction and draw its timing diagram.

Ans. DAD instruction adds the contents of a specified register pair to the contents of H and L.

For execution of DAD, 10 T-states are needed. Instead of having a single machine cycle having 10 T-states, it consists of the Opcode Fetch machine cycle (4T states) and 6 extra T-states divided into two machine cycles. These two extra machine cycles are Bus Idle Machine cycles which do not involve either memory or I/O.

The timing diagram for DAD instruction is shown below:

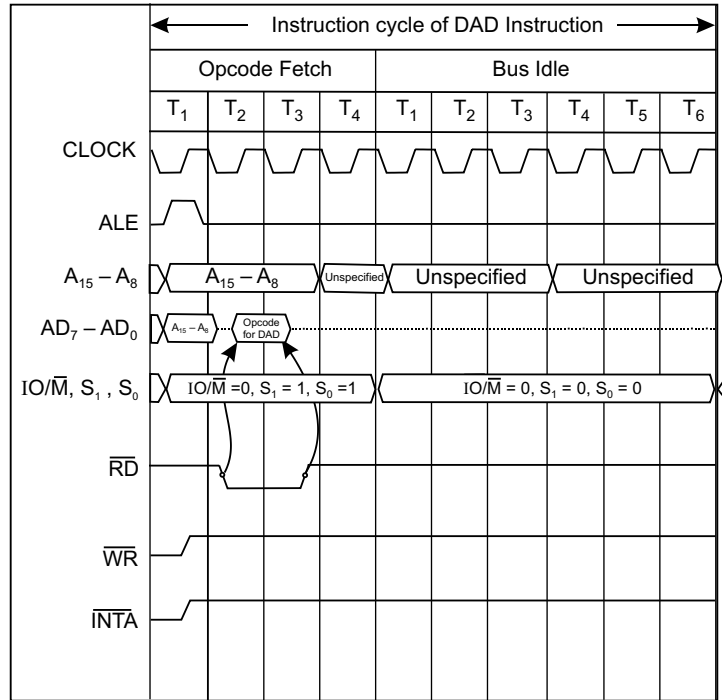

Fig. 2.18: Timing diagram for DAD instruction

56. Discuss the concept of WAIT states in microprocessors.

Ans. So many times it may happen that there is speed incompatibility between microprocessor and its memory and I/O systems. Mostly the microprocessor is having higher speed.

So in a given situation, if the microprocessor is ready to accept data from a peripheral device while there is no valid data in the device (e.g. an ADC), then the system enters into WAIT states and the READY pin (an input pin to the microprocessor, pin no. 35 for 8085) is put to a low state by the device.

Once the device becomes ready with some valid data, it withdraws the low state on the READY pin of 8085. Then 8085 accepts the data from the peripheral by software instructions.

57. Does 8085 have multiplication and division instructions?

Ans. No, 8085 does not have the above two instructions. It can neither multiply nor divide two 8-bit numbers. The same are executed by the processor following the process of repetitive addition or subtraction respectively.

58. Indicate the bus drive capability of 8085.

Ans. 8085 buses can source up to 400 μ A and sink 2 mA of current. Hence 8085 buses can drive a maximum of one TTL load.

Thus the buses need bus drivers/buffers to enhance the driving capability of the buses to ensure that the voltage levels are maintained at appropriate levels and malfunctioning is avoided.

59. What are the buffers needed with the buses of 8085?

Ans. An 8-bit unidirectional buffer 74LS244 is used to buffer the higher order address bus ($A_8 - A_{15}$). It consists of eight non-inverting buffers with tri-state outputs. Each pin can sink 24 mA and source 15 mA of current.

A bidirectional buffer 74LS245 (also called octal bus transceivers) can be used to drive the bidirectional data bus ($D_0 - D_7$) after its demultiplexing. The DIR pin of the IC controls the direction of flow of data through it.

60. Explain the instruction cycle of a microprocessor.

Ans. When a processor executes a program, the instructions (1 or 2 or 3 bytes in length) are executed sequentially by the system. The time taken by the processor to complete one instruction is called the Instruction Cycle (IC).

An IC consists of Fetch Cycle (FC) and an Execute Cycle (EC). Thus $IC = FC + EC$. It is shown in Fig. 2.19. Depending on the type of instruction, IC time varies.

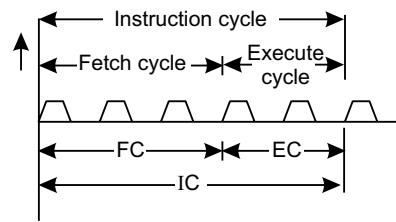

Fig. 2.19: Instruction cycle showing FC, EC and IC

61. Explain a typical fetch cycle (FC).

Ans. The time required to fetch an opcode from a memory location is called Fetch Cycle.

A typical FC may consist of 3T states. In the first T-state, the memory address, residing in the PC, is sent to the memory. The content of the addressed memory (i.e., the opcode residing in that memory location) is read in the second T-state, while in the third T-state this opcode is sent via the data bus to the instruction register (IR). For slow memories, it may take more time in which case the processor goes into 'wait cycles'. Most microprocessors have provision of wait cycles to cope with slow memories.

A typical FC may look like the following:

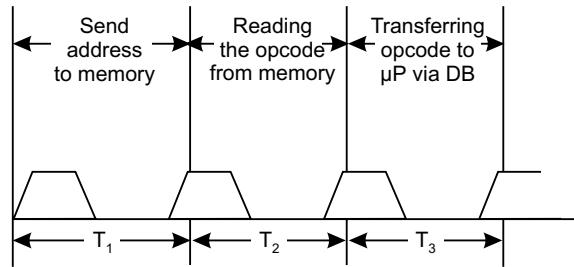

Fig. 2.20: A typical FC

62. Draw the block schematic of a typical Instruction Word flow diagram and explain the same.

Ans. There are two kinds of words—instruction word and data word. The 2 byte content of the PC is transferred to a special register—called memory address register (MAR) or simply address register (AR) at the beginning of the fetch cycle. Since the content of MAR is an address, it is thus sent to memory via the address bus. The content of the addressed memory is then read under 'Read control' generated by T&C section of the

microprocessor. This is then sent via the data bus to the memory data register (MDR) or simply data register (DR) existing in CPU. This is placed in the instruction register (IR) and is decoded by the instruction decoder and subsequently executed. The PC is then incremented if the subsequent memory location is to be accessed.

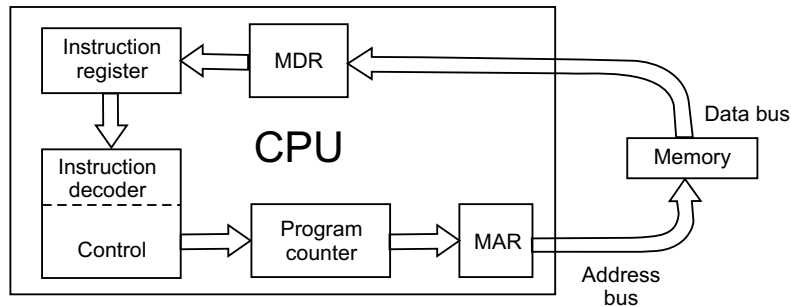

Fig. 2.21: Flow of instruction word

63. Draw the block schematic of a typical data word flow diagram and explain the same.

Ans. The data word flows via the data bus into the accumulator. The data source can be a memory device or an input device. Data from the accumulator is then manipulated in ALU under control of T & C unit. The manipulated data is then put back in the accumulator and can be sent to memory or output devices.

The block schematic of data flow is shown below.

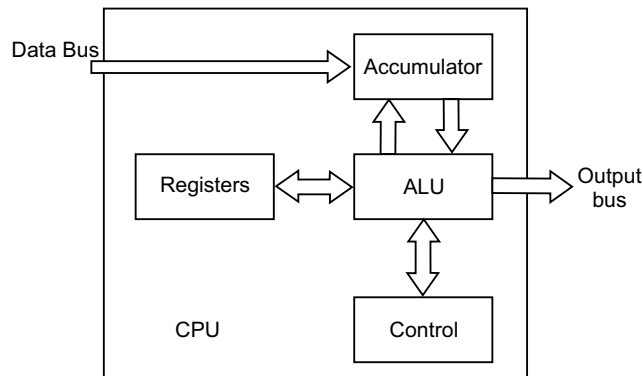

Fig. 2.22: Flow of data word

64. Why a microprocessor based system is called a sequential machine?

Ans. It can perform the jobs in a sequential manner, one after the other. That is why it is called a sequential machine.

65. Why a microprocessor based system is called a synchronous one?

Ans. All activities pertaining to the μP takes place in synchronism with the clock. Hence it is called a synchronous device.

66. Draw the diagram which will show the three buses separately, with the help of peripheral ICs.

Ans. The scheme of connections is shown below. The octal bus driver 74LS244 drives the higher order address bus $A_{15} - A_8$ while 74LS373 Latch drives the lower order address bus $A_7 - A_0$ (with the help of ALE signal). The bidirectional bus driver 74LS245 drives the data bus $D_7 - D_0$ while the 74LS138 (a 3 to 8 decoder chip) outputs at its output pins \overline{IOW} , \overline{IOR} , \overline{MEMW} , \overline{MEMR} signals from the $\overline{IO/\overline{M}}$, \overline{RD} and \overline{WR} signals of 8085.

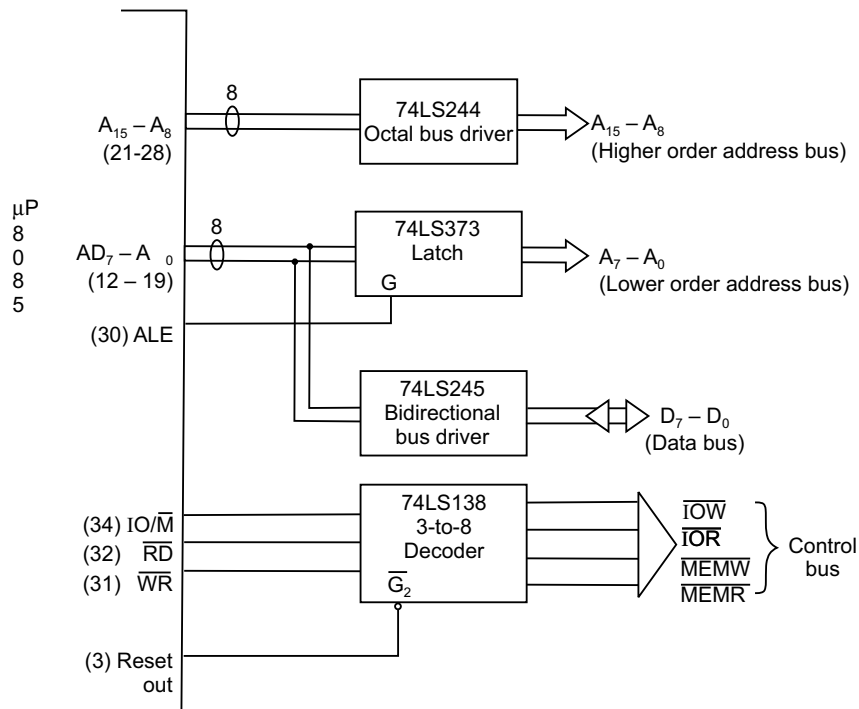

Fig. 2.23: Demultiplexing of address/data bus and separation of control signals

67. Discuss the status of \overline{WR} and \overline{RD} signals of 8085 at any given instant of time.

Ans. At any given instant, the status of the two signals \overline{WR} and \overline{RD} will be complementary to each other.

It is known that microprocessor based system is a sequential device, so that at any given point of time, it does the job of reading or writing—and definitely not the two jobs at the same time. Hence if \overline{WR} signal is low, then \overline{RD} signal must be high or vice versa.

68. Which registers of 8085 are programmable?

Ans. The registers B, C, D, E, H and L are programmable registers in that their contents can be changed by programming.

69. Suggest the type of operations possible on data from a look of the architecture of 8085.

Ans. The architecture of 8085 suggests that the following operations are possible.

- Can store 8-bits of data.
- Uses the temporary registers during arithmetic operations.
- Checks for the condition of resultant data (like carry, etc.) from the flag register.

70. What are the externally initiated operations supported by 8085?

Ans. 8085 supports several externally initiated operations at some of its pins. The operations possible are:

- Resetting (via Reset pin)
- Interruptions (via Trap, RST 7.5, RST 6.5, RST 5.5 and Interrupt pin)
- Ready (via Ready pin)
- Hold (via Hold pin)

71. Name the registers not accessible to the programmer.

Ans. The following registers cannot be accessed by the programmer:

- Instruction register (IR)
- Memory address register (MAR) or supply address register (AR)
- Temporary registers.

72. Name the special purpose registers of 8085.

Ans. The special purpose registers used in 8085 microprocessor are:

- Accumulator register (A)
- Program counter register (PC)
- Status (or Flag) register
- Stack pointer register (SP)

73. What should be the size of the Instruction Register if an arbitrary microprocessor has only 25 instructions?

Ans. The length of the Instruction Register would be 5-bits, since $2^5 = 32$, since a 5-bit Instruction Register can decode a maximum of 32 instructions.

74. Explain the difference between HLT and HOLD states.

Ans. HLT is a software instruction. Its execution stops the processor which enters into a HALT state and the buses of the processor are driven into tri-state.

HOLD is an hardware input to the processor. When HOLD input = 1, the processor goes into the HOLD state, but the buses don't go into tri-state. The processor gives out a high HLDA (hold acknowledge) signal which can be utilised by an external device (like a DMA controller) to take control of the processor buses. HOLD is acknowledged by the processor at the end of the current instruction execution.

75. Indicate the length of the Program Counter (PC) to access 1 KB and 1 MB memory.

Ans. 1 KB = 1024 bytes

and 1 MB = 1024 K bytes

Thus the required number of bits in PC to access 1 KB are 10 ($2^{10} = 1024$) and 20 ($2^{20} = 1024$ K) respectively.

76. What determines the number of bytes to be fetched from memory to execute an instruction?

Ans. An instruction normally consists of two fields. These are:

Opcode	Operand
--------	---------

Thus, while the system starts executing an instruction, it first decodes the opcode which then decides how many more bytes are to be brought from the memory—its minimum value is zero (like RAR) while the maximum value is two (like STA 4059 H).

77. A Microprocessor's control logic is 'microprogrammed'. Explain.

Ans. It implies that the architecture of the control logic is much alike the architecture of a very special purpose microprocessor.

78. Does the ALU have any storage facility?

Ans. No, it does not have any storage facility. For this reason, the need for temporary data registers arise in ALU—it has two inputs: one provided by the accumulator and the other from the temporary data register. The result of summation is stored in the accumulator.

Instruction Types and Timing Diagrams

1. What is an instruction?

Ans. An instruction is a command given to the microcomputer to perform a specific task or function on a given data.

2. What is meant by instruction set?

Ans. An instruction set is a collection of instructions that the microprocessor is designed to perform.

3. In how many categories the instructions of 8085 be classified?

Ans. Functionally, the instructions can be classified into five groups:

- data transfer (copy) group
- arithmetic group
- logical group
- branch group
- stack, I/O and machine control group.

4. What are the different types of data transfer operations possible?

Ans. The different types of data transfer operations possible are cited below:

- Between two registers.
- Between a register and a memory location.
- A data byte can be transferred between a register and a memory location.
- Between an I/O device and the accumulator.
- Between a register pair and the stack.

The term 'data transfer' is a misnomer—actually data is not transferred, but copied from source to destination.

5. Mention the different types of operations possible with arithmetic, logical, branch and machine control operations.

Ans. The arithmetic operations possible are addition, subtraction, increment and decrement.

The logical operations include AND, OR, EXOR, compare, complement, while branch operations are Jump, Call, Return and Restart instructions.

The machine control operations are Halt, Interrupt and NOP (no operation).

6. What are the different instruction word sizes in 8085?

Ans. The instruction word sizes are of the following types:

- 1-byte instruction
- 2-byte instruction
- 3-byte instruction.

7. What an instruction essentially consists of?

Ans. An instruction comprises of an operation code (called ‘opcode’) and the address of the data (called ‘operand’), on which the opcode operates. This is the structure on which an instruction is based. The opcode specifies the nature of the task to be performed by an instruction. Symbolically, an instruction looks like

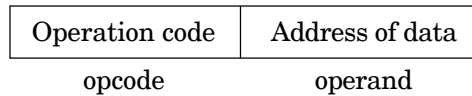

8. Give one example each of 1-byte, 2-byte and 3-byte instructions.

Ans. The examples are given below:

- 1-byte instruction : ADD B
- 2-byte instruction : MVIC, 07
- 3-byte instruction : LDA 4400

In 1-byte instruction, the opcode and the operand are in the same byte i.e.,

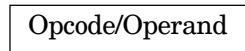

A 2-byte instruction looks like this:

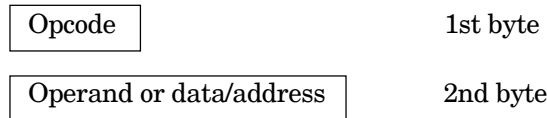

While a 3-byte instruction looks like the following:

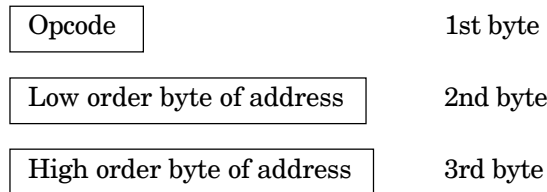

9. What is meant by ‘addressing mode’? Mention the different addressing modes.

Ans. Each instruction indicates an operation to be performed on certain data. There are various methods to specify the data for the instructions, known as ‘addressing modes’.

For 8085 microprocessor, there are five addressing modes. These are:

- Direct addressing
- Register addressing
- Register indirect addressing
- Immediate addressing
- Implicit addressing.

10. Give one example each of the five types of addressing modes.

Ans. The examples for each type of addressing mode are given below:

(a) *Direct Addressing:* In this mode, the operand is specified within the instruction itself.

Examples of this type are:

LDA 4000_H, STA 5513_H, etc.

IN/OUT instructions (like IN PORT C, OUT PORT B, etc.) also falls under this category.

- (b) *Register Addressing*: In this mode of addressing, the operand are in the general purpose registers.

Examples are: MOV A, B ; ADD D, etc.

- (c) *Register Indirect Addressing*: MOV A, M; ADD M are examples of this mode of addressing. These instructions utilise 1-byte. In this mode, instead of specifying a register, a register pair is specified to accommodate the 16-bit address of the operand.

- (d) *Immediate Addressing*: MVI A, 07; ADI 0F are examples of Immediate Addressing mode.

The operand is specified in the instruction in this mode. Here, the operand address is not specified.

- (e) *Implicit Addressing*: In this mode of addressing, the operand is fully absent. Examples are RAR, RAL, CMA, etc.

11. Let at the program memory location 4080, the instruction MOV B, A (opcode 47_H) is stored while the accumulator content is FF_H. Illustrate the execution of this instruction by timing diagram.

Ans. Since the program counter sequences the execution of instructions, it is assumed that the PC holds the address 4080_H. While the system executes the instruction, the following takes place one after another.

1. The CPU places the address 4080_H (residing in PC) on the address bus—40_H on the high order bus A₁₅ – A₈ and 80_H on the low order bus AD₇ – AD₀.
2. The CPU raises the ALE signal to go high—the H to L transition of ALE at the end of the first T state demultiplexes the low order bus.
3. The CPU identifies the nature of the machine cycle by means of the three status signals IO/ \bar{M} , S₀ and S₁.

$$IO/\bar{M} = 0, S_1 = 1, S_0 = 1$$

4. In T₂, memory is enabled by the \bar{RD} signal. The content of PC i.e., 47_H is placed on the data bus. PC is incremented to 4081_H.
5. In T₃, CPU reads 47_H and places it in the instruction register.
6. In T₄, CPU decodes the instruction, places FF_H (accumulator content) in the temporary register and then transfers it to register B. Figure 3.1 shows the execution of the above. It consists of 4T states.

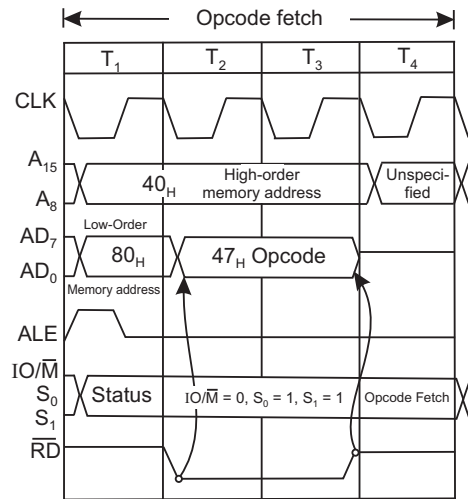

Fig. 3.1: 8085 timing for execution of the instruction (MOV B, A)

8085 Interrupts

1. Mention the interrupt pins of 8085.

Ans. There are five (5) interrupt pins of 8085—from pin 6 to pin 10. They represent TRAP, RST 7.5, RST 6.5, RST 5.5 and INTR interrupts respectively. These five interrupts are 'hardware' interrupts.

2. Explain maskable and non-maskable interrupts.

Ans. An interrupt which can be disabled by software means, is called a maskable interrupt. Thus an interrupt which cannot be masked is an unmaskable interrupt.

3. Which is the non-maskable interrupt for 8085?

Ans. TRAP interrupt is the non-maskable interrupt for 8085. It means that if an interrupt comes via TRAP, 8085 will have to recognise the interrupt.

4. Do the interrupts of 8085 have priority?

Ans. Yes, the interrupts of 8085 have their priorities fixed—TRAP interrupt has the highest priority, followed by RST 7.5, RST 6.5, RST 5.5 and lastly INTR.

5. What is meant by priority of interrupts?

Ans. It means that if 8085 is interrupted by more than one interrupt at the same time, the one which is having highest priority will be serviced first, followed by the one(s) which is (are) having just next priority and so on.

For example, if 8085 is interrupted by RST 7.5, INTR and RST 5.5 at the same time, then the sequence in which the interrupts are going to be serviced are as follows: RST 7.5, RST 5.5 and INTR respectively.

6. Mention the types of interrupts that 8085 supports.

Ans. 8085 supports two types of interrupts—hardware and software interrupts.

7. What are the software interrupts of 8085? Mention the instructions, their hex codes and the corresponding vector addresses.

Ans. 8085 has eight (8) software interrupts from RST 0 to RST 7. The instructions, hex codes and the vector locations are tabulated in Table 4.1:

Table 4.1: Vector addresses for software interrupts

Instruction	Corresponding HEX code	Vector addresses
RST 0	C7	0000H
RST 1	CF	0008H
RST 2	D7	0010H
RST 3	DF	0018H
RST 4	E7	0020H
RST 5	EF	0028H
RST 6	F7	0030H
RST 7	FF	0038H

8. How the vector address for a software interrupt is determined?

Ans. The vector address for a software interrupt is calculated as follows:

$$\text{Vector address} = \text{interrupt number} \times 8$$

For example, the vector address for RST 5 is calculated as

$$5 \times 8 = 40)_{10} = 28)_{H}$$

∴ Vector address for RST 5 is 0028_H.

9. In what way INTR is different from the other four hardware interrupts?

Ans. There are two differences, which are discussed below:

1. While INTR is not a vectored interrupt, the other four, viz., TRAP, RST 7.5, RST 6.5 and RST 5.5 are all vectored interrupts. Thus whenever an interrupt comes via any one of these four interrupts, the internal control circuit of 8085 produces a CALL to a predetermined vector location. At these vector locations the subroutines are written.
On the other hand, INTR receives the address of the subroutine from the external device itself.
2. Whenever an interrupt occurs via TRAP, RST 7.5, RST 6.5 or RST 5.5, the corresponding returns address (existing in program counter) is auto-saved in STACK, but this is not so in case of INTR interrupt.

10. Indicate the nature of signals that will trigger TRAP, RST 7.5, RST 6.5, RST 5.5 and INTR.

Ans. TRAP interrupt is both positive edge and level triggered, RST 7.5 is positive edge triggered while RST 6.5, RST 5.5 and INTR are all level triggered.

11. Why the TRAP input is edge and level sensitive?

Ans. TRAP input is edge and level sensitive to avoid false triggering caused by noise and transients.

12. Draw the TRAP interrupt circuit diagram and explain the same.

Ans.

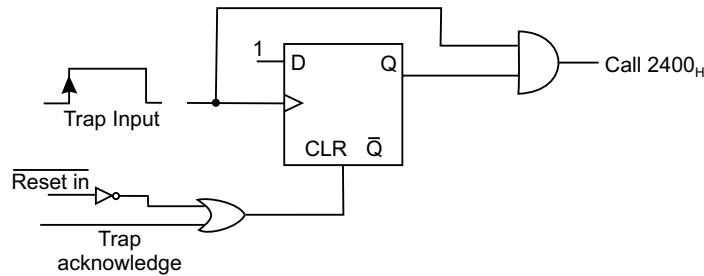

Fig. 4.1: The TRAP interrupt circuit

The positive edge of the TRAP signal sets the D F/F, so that Q becomes 1. It thus enables the AND gate, but the AND gate will output a 1 for a sustained high level at the TRAP input. In that case the subroutine written at vector memory location 2400_H corresponding to TRAP interrupt starts executing. 2400_H is the starting address of an interrupt service routine for TRAP.

There are two ways to clear the TRAP interrupt:

1. When the microprocessor is reset, then via the inverter, a high comes out of the OR gate, thereby clearing the D F/F, making $Q = 0$.
2. When a TRAP is acknowledged by the system, an internal TRAP ACKNOWLEDGE is generated thereby clearing the D F/F.

13. Discuss the INTR interrupt of 8085.

Ans. The following are the characteristics of INTR interrupt of 8085:

- It is a maskable interrupt
- It has lowest priority
- It is a non-vectored interrupt.

Sequentially, the following occurs when INTR signal goes high:

1. 8085 checks the status of INTR signal during execution of each instruction.
2. If INTR signal remains high till the completion of an instruction, then 8085 sends out an active low interrupt acknowledge (INTA) signal.
3. When INTA signal goes low, external logic places an instruction OP CODE on the data bus.
4. On receiving the instruction, 8085 saves the address of next instruction (which would have otherwise been executed) in the STACK and starts executing the ISS (interrupt service subroutine).

14. Draw the diagram that outputs RST 3 instruction opcode on acknowledging the interrupt.

Ans. The diagram is shown below:

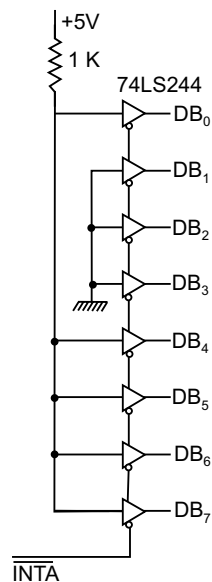

Fig. 4.2: Hardware circuit diagram to implement RST 3 (Opcode DF H)

When an INTR is acknowledged by the microprocessor, it outputs a low $\overline{\text{INTA}}$. Thus an RST 3 is gated onto the system bus. The processor then first saves the PC in the STACK and branches to the location 0018_{H} . At this address, the ISS begins and ends with a RET instruction. On encountering RET instruction in the last line of the ISS, the return address saved in the stack is restored in the PC so that normal processing in the main program (at the address which was left off when the program branched to ISS) begins.

15. What is to be done if a particular part of a program is not to be interrupted by RST 7.5, RST 6.5, RST 5.5 and INTR?

Ans. Two software instructions—EI and DI are used at the beginning and end of the particular portion of the program respectively. The scheme is shown schematically as follows:

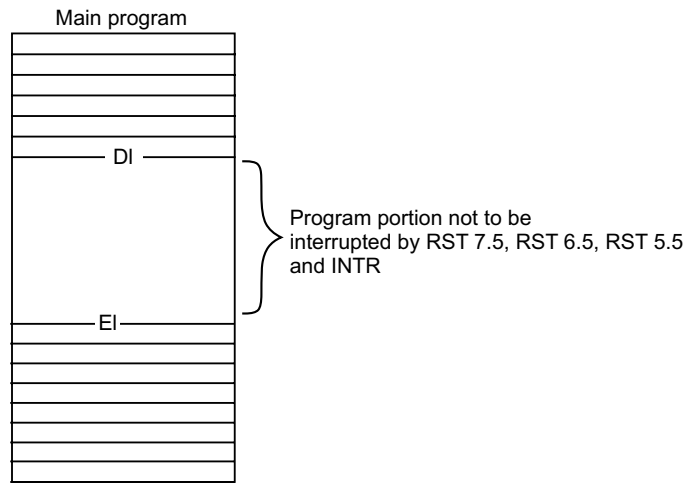

Fig. 4.3: Employing EI and DI in a program

16. Explain the software instructions EI and DI.

Ans. The EI instruction sets the interrupt enable flip-flop, thereby enabling RST 7.5, RST 6.5, RST 5.5 and INTR interrupts.

The DI instruction resets the interrupt enable flip-flop, thereby disabling RST 7.5, RST 6.5, RST 5.5 and INTR interrupts.

17. When returning back to the main program from Interrupt Service Subroutine (ISS), the software instruction EI is inserted at the end of the ISS. Why?

Ans. When an interrupt (either via RST 7.5, RST 6.5, RST 5.5, INTR) is acknowledged by the microprocessor, 'any interrupt acknowledge' signal resets the interrupt enable F/F. It thus disables RST 7.5, RST 6.5, RST 5.5 and INTR interrupts. Thus any future interrupt coming via RST 7.5, RST 6.5, RST 5.5 or INTR will not be acknowledged unless the software instruction EI is inserted which thereby sets the interrupt enable F/F.

18. Mention the ways in which the three interrupts RST 7.5, RST 6.5 and RST 5.5 are disabled?

Ans. The three interrupts can be disabled in the following manner:

- Software instruction DI
- $\overline{\text{RESET IN}}$ signal
- Any interrupt acknowledge signal.

19. Draw the SIM instruction format and discuss.

Ans. The SIM instruction format is shown below:

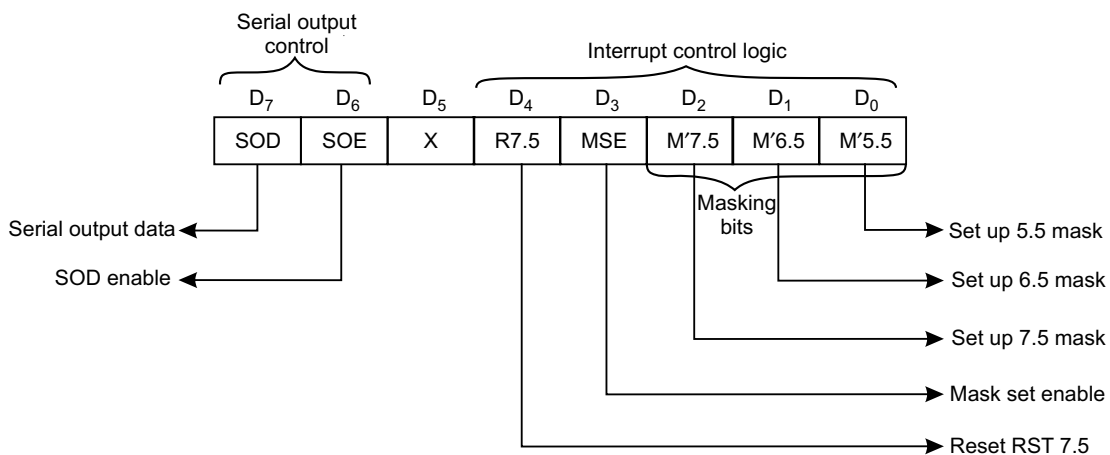

Fig. 4.4: The SIM instruction format

D_7 and D_6 bits are utilised for serial outputting of data from accumulator. D_5 bit is a don't care bit, while bits D_4 – D_0 are used for interrupt control.

D_4 bit can clear the D F/F associated with RST 7.5.

D_3 bit is mask set enable (MSE) bit, while bits D_2 – D_0 are the masking bits corresponding to RST 7.5, RST 6.5 and RST 5.5 respectively.

None of the flags are affected by SIM instruction.

By employing SIM instruction, the three interrupts RST 7.5, RST 6.5 and RST 5.5 can be masked or unmasked. For masking any one of these three interrupts, MSE (i.e., bit D_3) bit must be 1.

For example let RST 7.5 is to be masked (disabled), while RST 6.5 and RST 5.5 are to be unmasked (enabled), then the content of the bits of the SIM instruction will be like

$$0000\ 1100 = 0C_H$$

For this to be effective the following two instructions are written,

MVI A, 0C_H

SIM

Execution of SIM instruction allows copying of the contents of the accumulator into the interrupt masks.

20. Show the RIM instruction format and discuss the same.

Ans. RIM stands for ‘Read interrupt mask’ and its format is as follows:

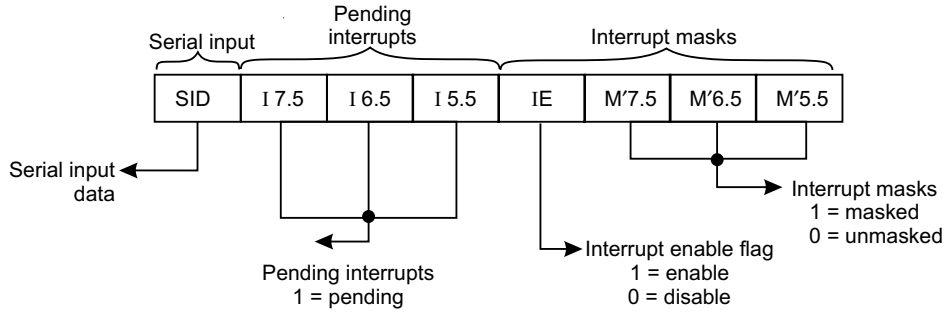

Fig. 4.5: The RIM instruction format

When RIM instruction is executed in software, the status of SID, pending interrupts and interrupt masks are loaded into the accumulator. Thus their status can be monitored. It may so happen that when one interrupt is being serviced, other interrupt(s) may occur. The status of these pending interrupts can be monitored by the RIM instruction. None of the flags are affected by RIM instruction.

21. Write a program which will call the interrupt service subroutine (at 3C00H) corresponding to RST 7.5 if it is pending. Let the ACC content is 20 H on executing the RIM instruction.

Ans. The program for the above will be as hereunder:

		SID	I7.5	I6.5	I5.5	IE	M'7.5	M'6.5	M'5.5
RIM	⇒ ACC	0	0	1	0	0	0	0	0
ANI 40 H	⇒ AND immediate with 40 H	0	1	0	0	0	0	0	0
Isolate 17.5 bit									
CNZ 3C00H	⇒ Call interrupt service subroutine corresponding to RST 7.5, if RST 7.5 is pending.								

22. Write a program which will call the subroutine (say named ‘SR’) if RST 6.5 is masked. Let content of ACC is 20 H on executing the RIM instruction.

Ans. RST 6.5 is masked if bit M'6.5 (D₁ bit of RIM) is a 1 and also D₃ bit (i.e., IE) is 1
The program for the above will be as hereunder:

		SID	I7.5	I6.5	I5.5	IE	M'7.5	M'6.5	M'5.5
RIM	⇒ ACC	0	0	1	0	0	0	0	0
ANI 0A H	⇒ AND immediate with 0A H	0	0	0	0	1	0	1	0
Isolate M'6.5 bit									
JNZ SR	⇒ Jump to subroutine “SR” if RST 6.5 is masked.								

23. For what purpose TRAP interrupt is normally used?

Ans. TRAP interrupt is a non-maskable one i.e., if an interrupt comes via the TRAP input, the system will have to acknowledge that. That is why it is used for vital purposes which require immediate attention like power failure.

If the microprocessor based system loses power, the filter capacitors hold the supply voltage for several milli seconds.

During this time, data in the RAM can be written in a disk or E²PROM for future usage.

24. Draw the interrupt circuit diagram for 8085 and explain.

Ans. Figure 4.6 is the interrupt circuit diagram of 8085. It shows the five hardware interrupts TRAP, RST 7.5, RST 6.5, RST 5.5 and INTR along with the software interrupts RST n: n = 0 to 7.

Trap is both edge and level sensitive interrupt. A short pulse should be applied at the trap input, but the pulse width must be greater than a normal noise pulse width and also long enough for the μ P to complete its current instruction. The trap input must come down to low level for it to be recognised for the second time by the system. It is having highest priority.

Next highest priority interrupt is RST 7.5 which responds to the positive edge (low to high transition) of a pulse. Like trap, it also has a D F/F whose output becomes 1 on accepting the RST 7.5 input, but final call to vector location 3C00H is reached only if RST 7.5 remains unmasked and the program has an EI instruction inserted already. These are evident from the circuit. If R 7.5 (bit D₄ of SIM instruction) is 1, then RST 7.5 instruction will be overlooked i.e., it can override any RST 7.5 interrupt.

Like RST 7.5, final call locations 3400_H and 2C00_H corresponding to interrupts at RST 6.5 and RST 5.5 are reached only if the two interrupts remain unmasked and the software instruction EI is inserted.

The three interrupts RST 7.5, RST 6.5 and RST 5.5 are disabled once the system accepts an interrupt input via any one of these pins—this is because of the generation of ‘any interrupt acknowledge’ signal which disables them.

Any of the software RST instructions (RST n : n = 0 to 7) can be utilised by using INTR instruction and hardware logic. RST instructions are utilised in breakpoint service routine to check register(s) or memory contents at any point in the program.

25. The process of interrupt is asynchronous in nature. Why?

Ans. Interrupts may come and be acknowledged (provided masking of any interrupt is not done) by the microprocessor without any reference to the system clock. That is why interrupts are asynchronous in nature.

26. In how many categories can ‘interrupt requests’ be classified?

Ans. The ‘interrupt requests’ can be classified into two categories—maskable interrupt and non-maskable interrupt.

A maskable interrupt can either be ignored or delayed as per the needs of the system while a non-maskable interrupt has to be acknowledged.

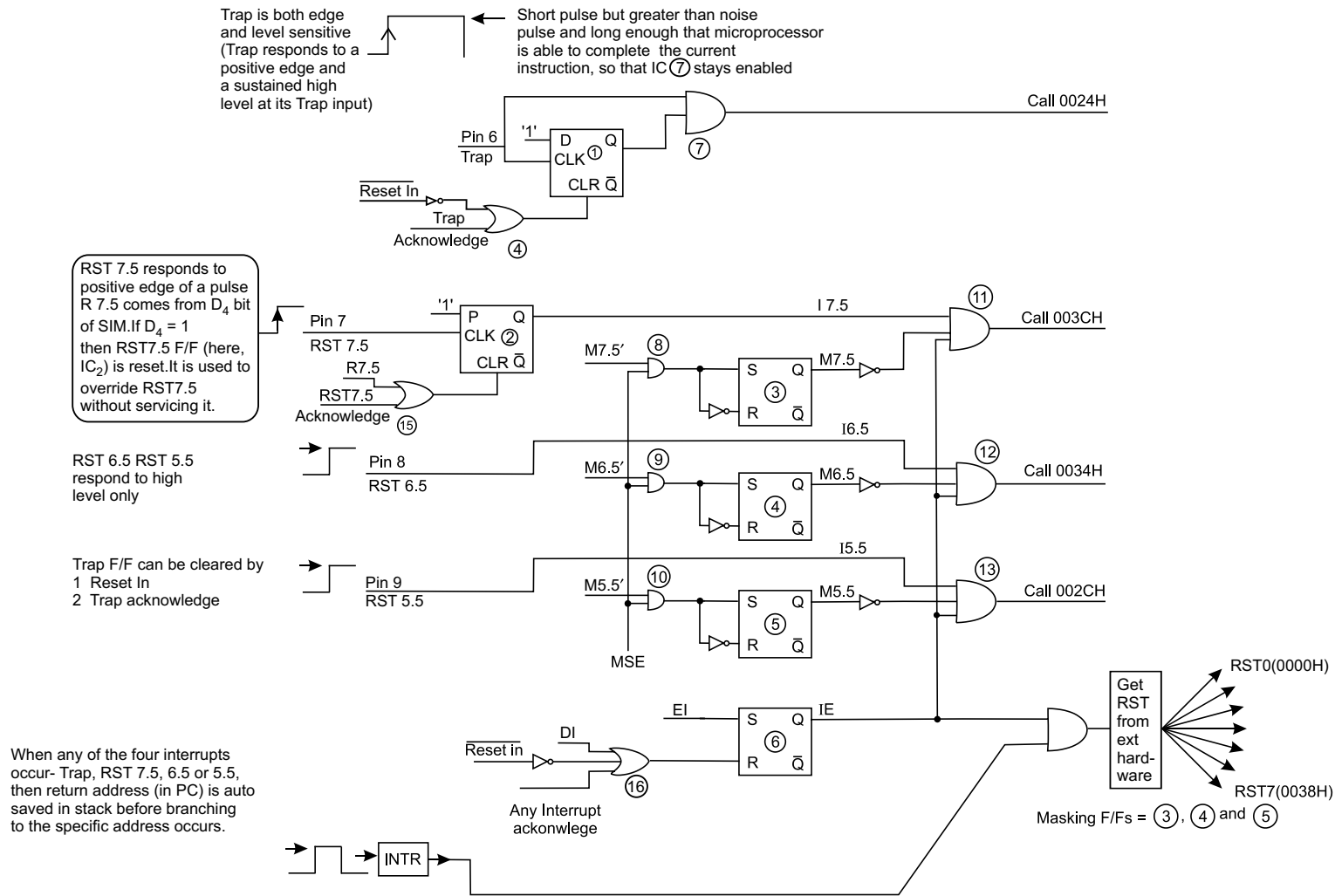

Fig. 4.6: Interrupt circuit description

27. When the interrupt pins of 8085 are checked by the system?

Ans. Microprocessor checks (samples) interrupt pins one cycle before the completion of an instruction cycle, on the falling edge of the clock pulse. An interrupt occurring at least 160 ns (150 ns for 8085A-2, since it is faster in operation) before the sampling time is treated as a valid interrupt.

28. Is there a minimum pulse width required for the INTR signal?

Ans. Microprocessor issues a low \overline{INTA} signal as an acknowledgement on receiving an INTR interrupt input signal. A CALL instruction is then issued so that the program branches to Interrupt Service Subroutine (ISS). Now the CALL requires 18 T-states to complete. Hence the INTR pulse must remain high for at least 17.5 T-states. If 8085 is operated at 3 MHz clock frequency, then the INTR pulse must remain high for at least 5.8 μ S.

29. Can the microprocessor be interrupted before completion of existing Interrupt Service Subroutine (ISS)?

Ans. Yes, the microprocessor can be interrupted before the completion of the existing ISS.

Let after acknowledging the INTR, the microprocessor is in the ISS executing instructions one by one. Now, for a given situation, if the interrupt system is enabled (by inserting an EI instruction) just after entering the ISS, the system can be interrupted again while it is in the first ISS.

If an interrupt service subroutine be interrupted again then this is called 'nested interrupt'.

30. Bring out one basic difference between SIM and DI instructions.

Ans. While by using SIM instruction any combinations or all of RST 7.5, RST 6.5 and RST 5.5 can be disabled, on the other hand DI disables RST 7.5, RST 6.5, RST 5.5 and in addition INTR interrupt also.

31. What is RIM instruction and what does it do?

Ans. The instruction RIM stands for Read Interrupt Mask. By executing this instruction in software, it is possible to know the status of interrupt mask, pending interrupt(s), and serial input.

32. In an interrupt driven system, EI instruction should be incorporated at the beginning of the program. Why?

Ans. A program, written by a programmer in the RAM location, is started first by system reset and loading the PC with the starting address of the program.

Now, with a system reset, all maskable interrupts are disabled. Hence, an EI instruction must be put in at the beginning of the program so that the maskable interrupts, which should remain unmasked in a program, remain so.

33. How the system can handle multiple interrupts?

Ans. Multiple interrupts can be handled if a separate interrupt is allocated to each peripheral.

The programmable interrupt controller IC 8259 can also be used to handle multiple interrupts when they are interfaced through INTR.

34. When an interrupt is acknowledged, maskable interrupts are automatically disabled. Why?

Ans. This is done so that the interrupt service subroutine (ISS) to which the program has entered on receiving the interrupt, has a chance to complete its own task.

35. What is meant by ‘nested interrupts’? What care must be taken while handling nested interrupts?

Ans. Interrupts occurring within interrupts are called ‘nested interrupts’.

While handling nested interrupts, care must be taken to see that the stack does not grow to such an extent as to foul the main program—in that case the system program fails.

36. ‘A RIM instruction should be performed immediately after TRAP occurs’—Why?

Ans. This is so as to enable the pre-TRAP interrupt status to be restored with the implementation of a SIM instruction.

37. What does the D₄ bit of SIM do?

Ans. Bit D₄ of SIM is R 7.5 which is connected to RST 7.5 F/F via a OR gate. If D₄ of SIM is made a 1, then it resets RST 7.5 F/F. This thus can be used to override RST 7.5 without servicing it.

38. Comment on the TRAP input of 8085.

Ans. Trap input is both edge and level sensitive. It is a narrow pulse, but the pulse width should be more than normal noise pulse width. This is done so that noise cannot affect the TRAP input with a false triggering. Again the pulse width should be such that the TRAP input which is directly connected to the gate stays high till the completion of current instruction by the μ P. In that case, only the program gets diverted to vector call location 2400 H.

TRAP cannot respond for a second time until the first TRAP goes through a high to low transition.

TRAP interrupt, once acknowledged, goes to 2400 H vector location without any external hardware or EI instruction, as is the case for other interrupt signals to be acknowledged.

39. Discuss about the triggering levels of RST 7.5, RST 6.5 and RST 5.5.

Ans. RST 7.5 is positive edge sensitive and responds to a short trigger pulse. The interrupt that comes via RST 7.5 is stored in a D F/F, internal to μ P. The final vector call location 3C00 H is invoked only if RST 7.5 remains unmasked via SIM and software instruction EI is inserted in the program.

RST 6.5 and 5.5 respond to high level (i.e., level sensitive) at their input pins—thus these two pins must remain high until microprocessor completes the execution of the current instruction.

40. Discuss the utility of RST software instruction.

Ans. For an RST instruction (RST n, n : 0 to 7) to become effective, external hardware is necessary, along with INTR interrupt instruction.

When debugging is required in a program to know the register(s) or memory contents, breakpoints are inserted via RST instruction.

A breakpoint is an RST instruction inserted in a program. When an RST instruction is recognised, the program control is transferred to the corresponding RST vector location. From this vector location, it is again transferred to the breakpoint service routine so that programmer can check the contents of any register or memory content on pressing specified key(s). After testing, the routine returns to the breakpoint in the main program.

Thus RST instructions can be inserted within a program to examine the register/memory content as per the requirement.

41. Under what condition, an RST instruction is going to be recognised?

Ans. Any RST instruction is recognised only if the EI instruction is incorporated via software.

42. Can the 'TRAP' interrupt be disabled by a combination of hardware and software?

Ans. Yes, it can be disabled by SIM instruction and hardware, as shown in Fig. 4.7.

The following two instructions are executed.

MVIA, 40 H

SIM

It ensures that a '0' logic comes out via SOD pin (pin 4) of 8085. This is then ANDed with TRAP input.

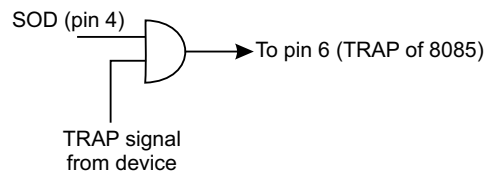

Fig. 4.7

Thus pin 6 (TRAP) always remains at '0' logic and hence TRAP input is disabled or 'MASKED'.

43. Level wise, how the interrupts can be classified? Distinguish them.

Ans. Level wise, interrupts can be classified as

- single level interrupts
- multi level interrupts

Their distinguishing features are shown below:

Single level interrupt	Multi level interrupt
1. Interrupts are fed via a single pin of microprocessor (like INTR of 8085)	1. Interrupts are fed via different pins of microprocessor (like RST 7.5, RST 6.5 etc), each interrupt requiring a separate pin of microprocessor.
2. CPU polls the I/O devices to identify the interrupting device.	2. Since each interrupt pin corresponds to a single I/O device, polling is not necessary.
3. Slower because of sl. no. 2.	3. Faster because of sl. no. 2.